

VORTEX FLOAT VALVE

PARTS IDENTIFICATION SHEET

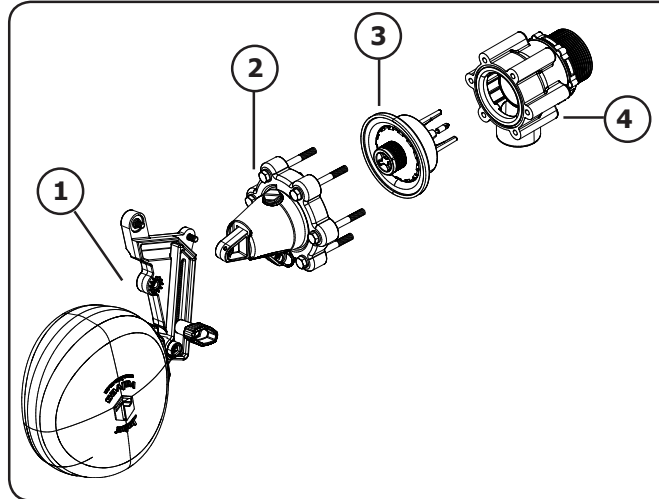

CODE	DESCRIPTION
1	VXP1 Float Assembly
2	VXP2 Cap & Actuator Assembly
3	VXP3 Diaphragm Assembly
4	Base Assembly

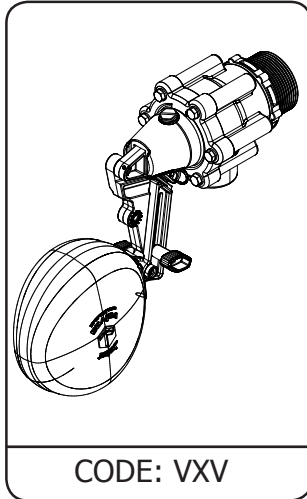
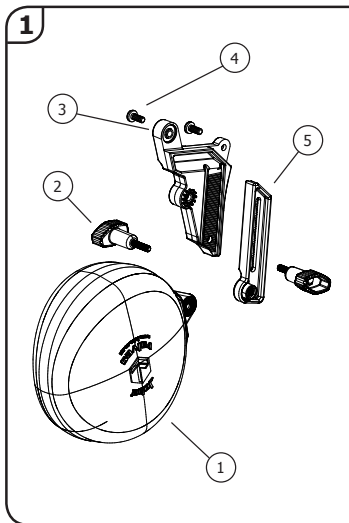

CODE	DESCRIPTION
1	VXP1010 70mm Float
2	VXP1020 Wing Bolt
3	VXP1030 Extension Arm
4	VXP1040 Bolt M5 x 12 Pan Slot
5	VXP1050 Extension Slide

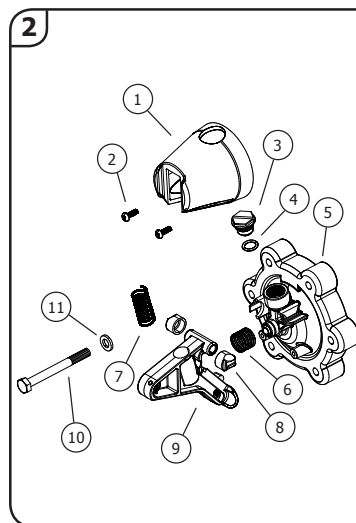

CODE	DESCRIPTION
1	VXP2010 Actuator Cap
2	VXP2020 6g x 10 S/S Screw
3	VXP2030 Frost Pro Plug
4	VXP2040 Frost Pro O'ring
5	VXP2050 Valve Cap Assembly
6	VXP2060 Damping Spring
7	VXP2070 Actuator Spring
8	VXP2080 Bearings (set of two)
9	VXP2090 Actuator Arm
10	VXP2100 Bolt M6 x 65
11	VXP2110 Washer M6 x 12.5

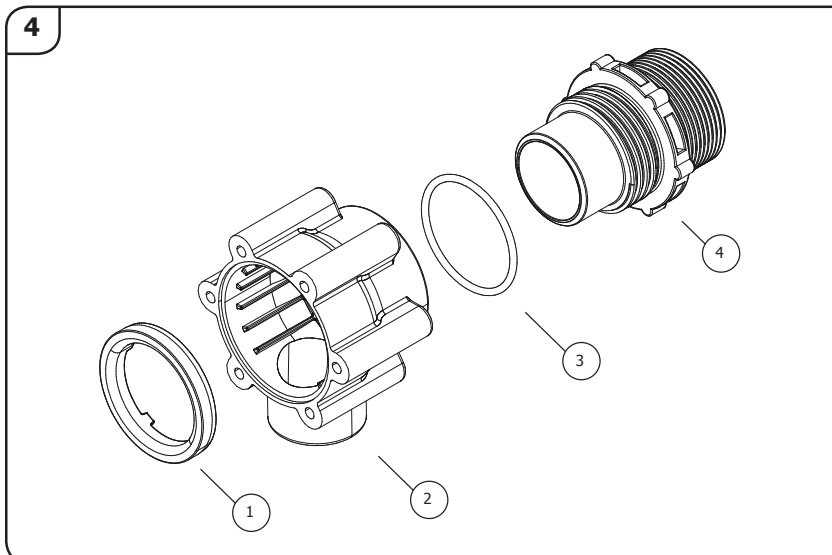

CODE	DESCRIPTION
1	VXP4010 Vortex Retainer
2	VXP4020 Vortex Base
3	VXP4030 Vortex O'ring
4	VXP4040 Vortex Tail 32mm
	VXP4045 Vortex Tail 40mm
	VXP4050 Vortex Tail 50mm
	VXP4055 Vortex Tail 1 1/4" NPT
	VXP4060 Vortex Tail 1 1/2" NPT
	VXP4065 Vortex Tail 2" NPT