

# VORTEX PARTFILL

## PARTS IDENTIFICATION SHEET

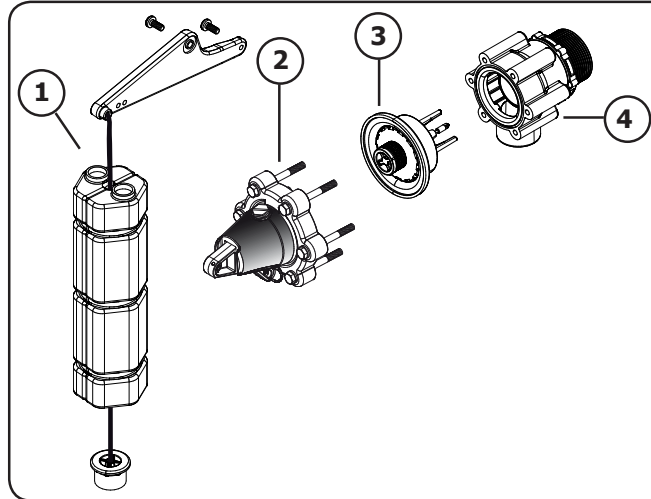

CODE	DESCRIPTION
1 VXPP1	Float Assembly
2 VXPP2	Cap & Actuator Assembly
3 VXPP3	Diaphragm Assembly
4	Detach Base Assembly

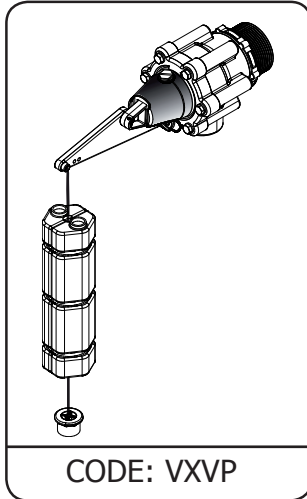
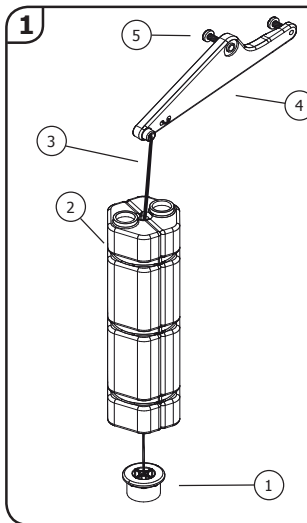

CODE	DESCRIPTION
1 VXPP1010	Bottom Stop
2 VXPP1020	Weighted Float
3 VXPP1030	Cord
4 VXPP1040	Arm Extension
5 VXPP1050	M5 x 12 Bolt

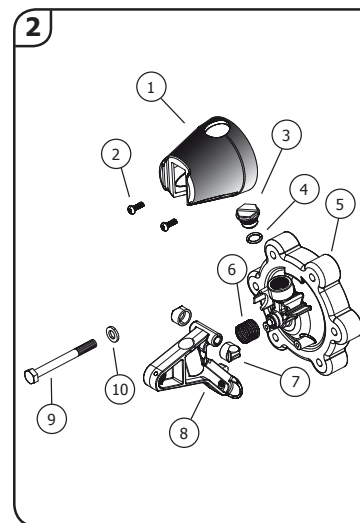

CODE	DESCRIPTION
1 VXPP2010	Actuator Cap
2 VXPP2020	6g x 10 S/S Screw
3 VXPP2030	Frost Pro Plug
4 VXPP2040	Frost Pro O'ring
5 VXPP2050	Valve Cap Assembly
6 VXPP2060	Damping Spring
7 VXPP2070	Bearings (set of two)
8 VXPP2080	Actuator Arm
9 VXPP2090	Bolt M6 x 65
10 VXPP2100	Washer M6 x 12.5

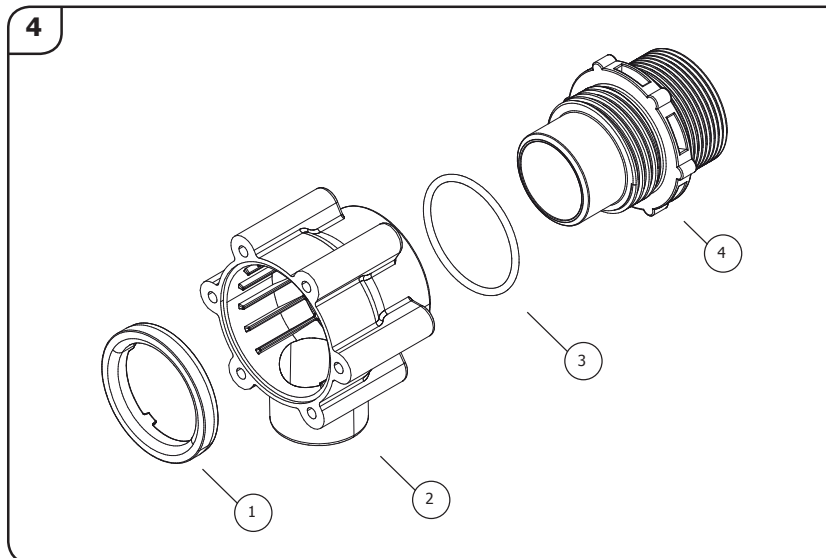

CODE	DESCRIPTION
1 VXPP4010	Vortex Retainer
2 VXPP4020	Vortex Base
3 VXPP4030	Vortex O'ring
4 VXPP4040	Vortex Tail 32mm
VXPP4045	Vortex Tail 40mm
VXPP4050	Vortex Tail 50mm
VXPP4055	Vortex Tail 1 1/4" NPT
VXPP4060	Vortex Tail 1 1/2" NPT
VXPP4065	Vortex Tail 2" NPT