

VORTEX DIFFERENTIAL

PARTS IDENTIFICATION SHEET

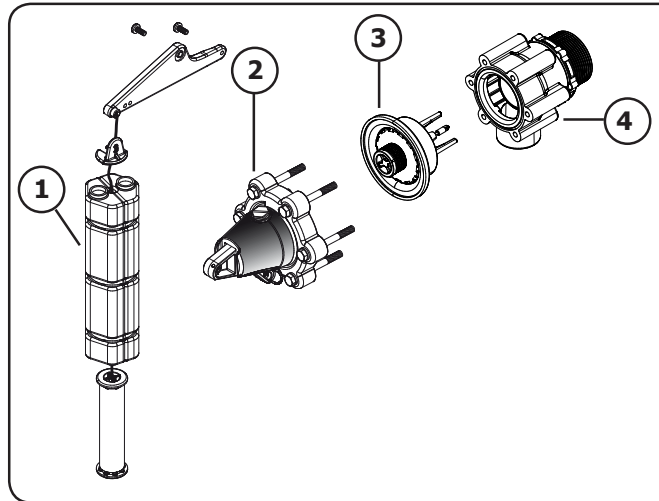

CODE	DESCRIPTION
1	VXPD1 Float Assembly
2	VXPD2 Cap & Actuator Assembly
3	VXPD3 Diaphragm Assembly
4	Base Assembly

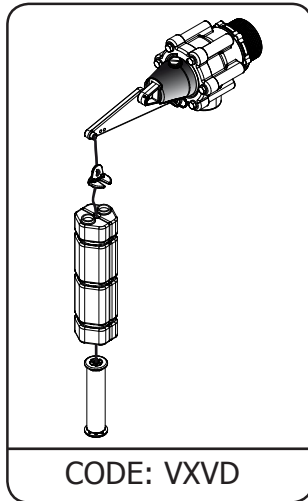
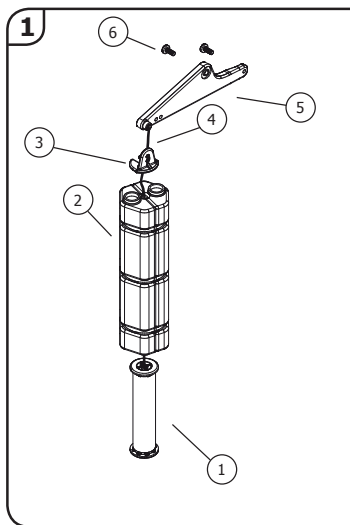

CODE	DESCRIPTION
1	VXPD1010 Weighted Tube Stop
2	VXPD1020 Weighted Float
3	VXPD1030 Upper Float Stop
4	VXPD1040 Cord
5	VXPD1050 Arm Extension
6	VXPD1060 M5 x 12 Bolt

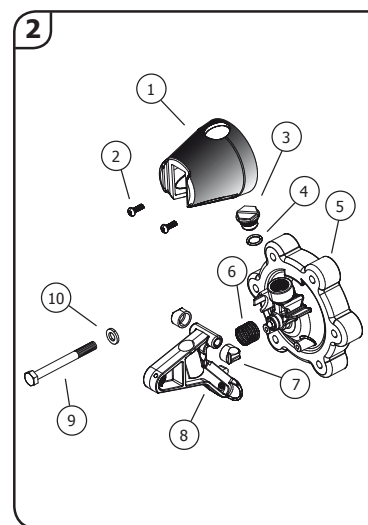

CODE	DESCRIPTION
1	VXPD2010 Actuator Cap
2	VXPD2020 6g x 10 S/S Screw
3	VXPD2030 Frost Pro Plug
4	VXPD2040 Frost Pro O'ring
5	VXPD2050 Valve Cap Assembly
6	VXPD2060 Damping Spring
7	VXPD2070 Bearings (set of two)
8	VXPD2080 Actuator Arm
9	VXPD2090 Bolt M6 x 65
10	VXPD2100 Washer M6 x 12.5

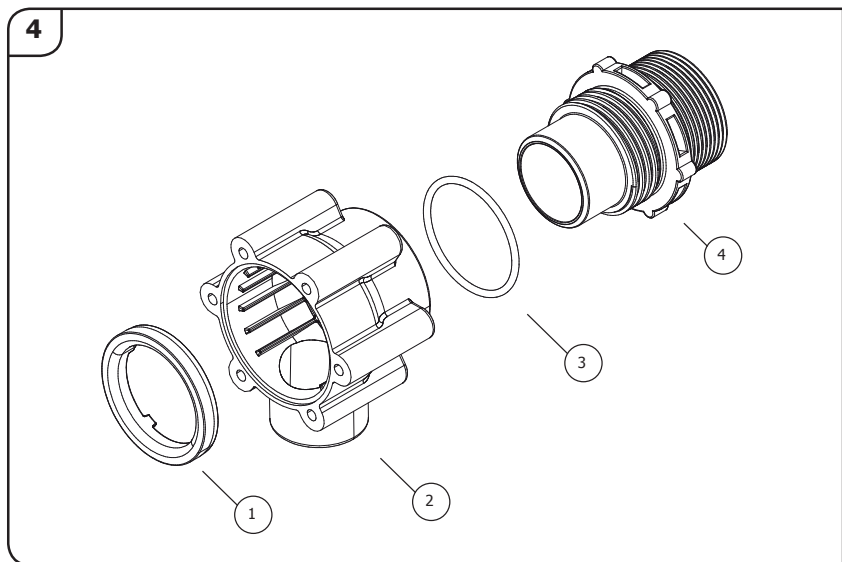

CODE	DESCRIPTION
1	VXPD4010 Vortex Retainer
2	VXPD4020 Vortex Base
3	VXPD4030 Vortex O'ring
4	VXPD4040 Vortex Tail 32mm
	VXPD4045 Vortex Tail 40mm
	VXPD4050 Vortex Tail 50mm
	VXPD4055 Vortex Tail 1 1/4" NPT
	VXPD4060 Vortex Tail 1 1/2" NPT
	VXPD4065 Vortex Tail 2" NPT