



Parts Identification Sheet

TOPAZ DIFFERENTIAL



CODE: TPV

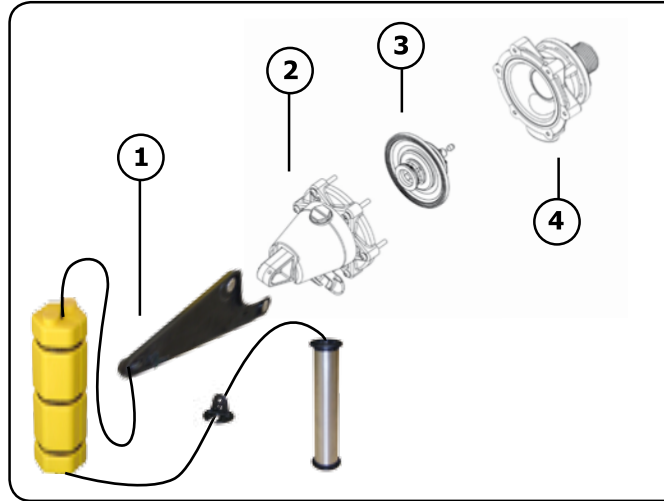

CODE	DESCRIPTION	
1	TPDP101	Float, Arm & Weight Assembly
2	TPDP21	Cap & Actuator Assembly
3	TPP3	Diaphragm Assembly
4		Detach Base Assembly

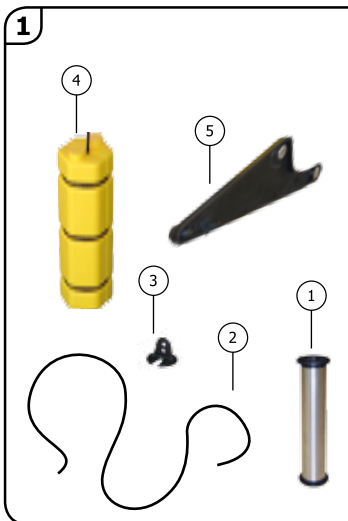

CODE	DESCRIPTION	
1	TPDP1010	Weighted Tube Stop
2	TPDP1020	Nylon Cord
3	TPDP1030	Upper Float Stop
4	TPDP1040	Weighted Float
5	TPDP1050	Arm Extension

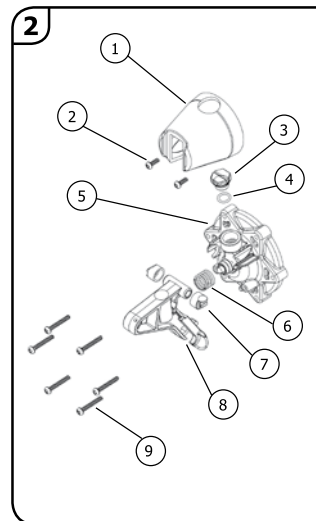

CODE	DESCRIPTION	
1	TPDP2011	Actuator Cap
2	TPP2020	6g x 10 S/S Screw
3	TPP2030	Frost Pro Plug
4	TPP2040	Frost Pro O'ring
5	TPP2050	Valve Cap Assembly
6	TPDP2061	Damping Spring
7	TPP2070	Bearings (set of two)
8	TPP2080	Actuator Arm
9	TPP2090	6g x 25 S/S Screw

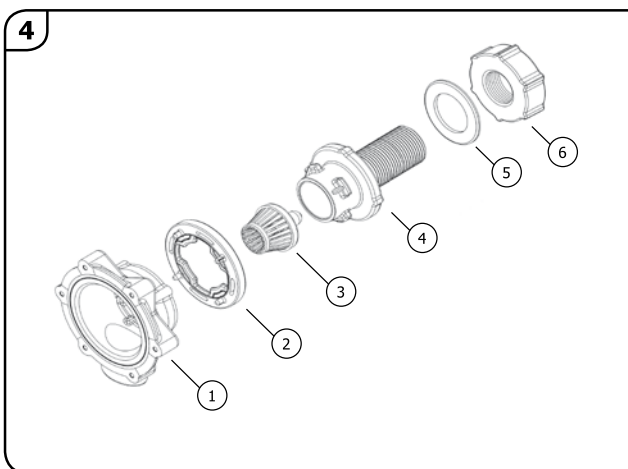

CODE	DESCRIPTION	
1	TPP4A010	Detach Base
2	TPP4A020	Detach Seal
3	TPP4A030	Detach Filter
4	TPP4A0410	Detach Tail 15mm (1/2") Long
	TPP4A0420	Detach Tail 20mm (3/4") Long
	TPP4A0426	Detach Tail 25mm (1") Long
	TPP4A0427	Detach Tail 1" NPT Long
	TPP4A0436	Detach Tail 32mm (1 1/4") Long
	TPP4A0437	Detach Tail 1 1/4" NPT Long
5	TPP4A050	Seal Washer 15mm (1/2")
	TPP4A051	Seal Washer 20mm (3/4")
	TPP4A052	Seal Washer 25mm (1")
	TPP4A053	Seal Washer 32mm (1 1/4")
6	TPP4A060	Backnut 15mm (1/2")
	TPP4A062	Backnut 20mm (3/4")
	TPP4A063	Backnut 25mm (1")
	TPP4A064	Backnut 32mm (1 1/4")