

VORTEX PARTFILL

PRODUCT INFO



Description

Vortex Part Fill is a high flow valve intended for use in rain water harvesting tanks. The purpose of the float valve is to automatically maintain a low level of water in the tank during periods of no or low rainfall. This allows services fed by the tank to continue while leaving capacity in the tank for refilling by the next rain.

Applications

- Maintaining water levels in:
- Rain water harvesting tanks
 - Water cisterns
 - Irrigation and process applications.

Flow Graph (All Sizes)

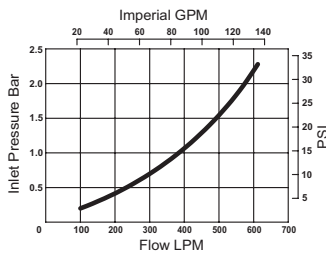

Features

- Ideal for use with all makes and models of rain water harvesting tanks
- Compact
- Constructed from non corroding materials
- Built in non return valve
- Valve can be locked in off position using the lock off switch
- Up to 150mm differential obtainable (dependant on pressure)
- Valve unscrews from tail for easy Valve Access.

Available Inlet Sizes

VXVP32	32mm (1 1/4")
VXVP40	40mm (1 1/2")
VXVP50	50mm (2")
VXVP114	1 1/4" NPT
VXVP112	1 1/2" NPT
VXVP2	2" NPT

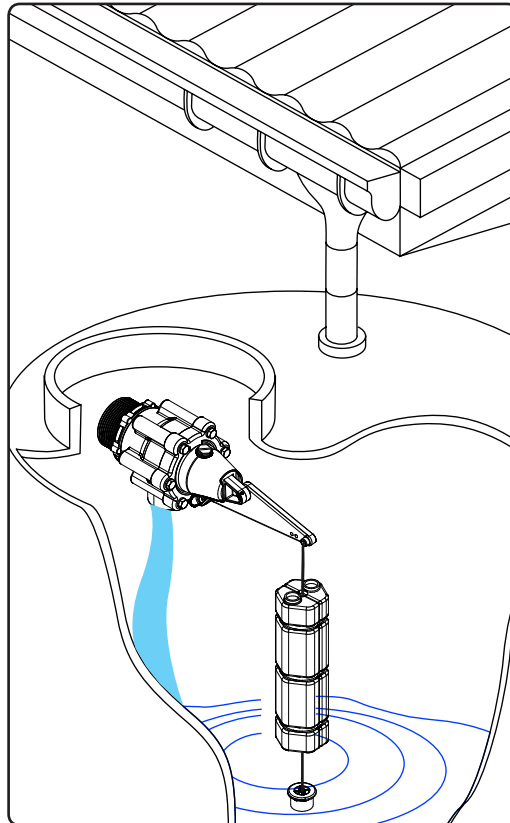

Principle of Operation

- The Valve is installed through the side wall of a storage tank. It should be mounted above the overflow level of the tank to prevent backflow.
- As the tank empties the weighted float travels down the cord and sits on the bottom stop to activate the valve.
- The valve will run until the weighted float lifts clear of the bottom stop.
- The float will then rise as rainwater fills the tank and falls as the tank water is used.
- The Valve will only function at times when rain fall is insufficient to maintain a water level in the tank above the botto stop.

Pressure Range

0.3 Bar – 10 Bar (5 psi-150 psi)

Typical Installaton

Vortex Part Fill Operating Zone

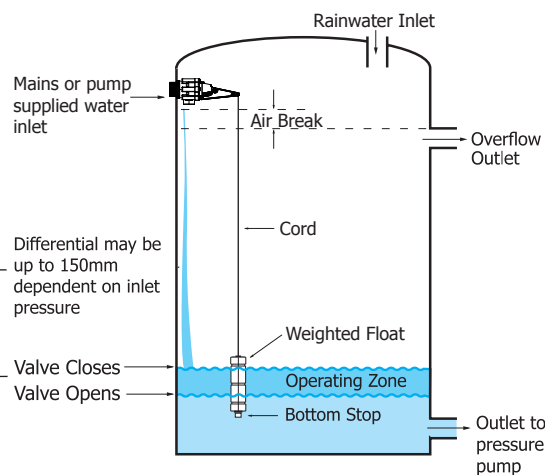

Rain Water Filling Zone

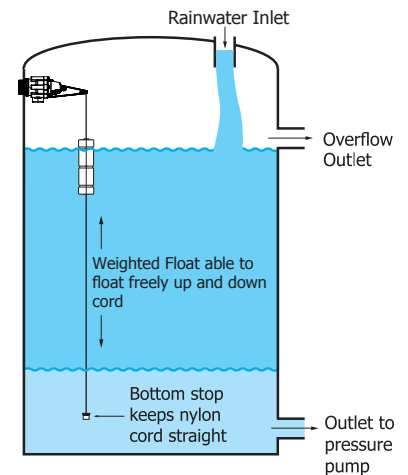

VORTEX PARTFILL

DIMENSIONS & MATERIALS

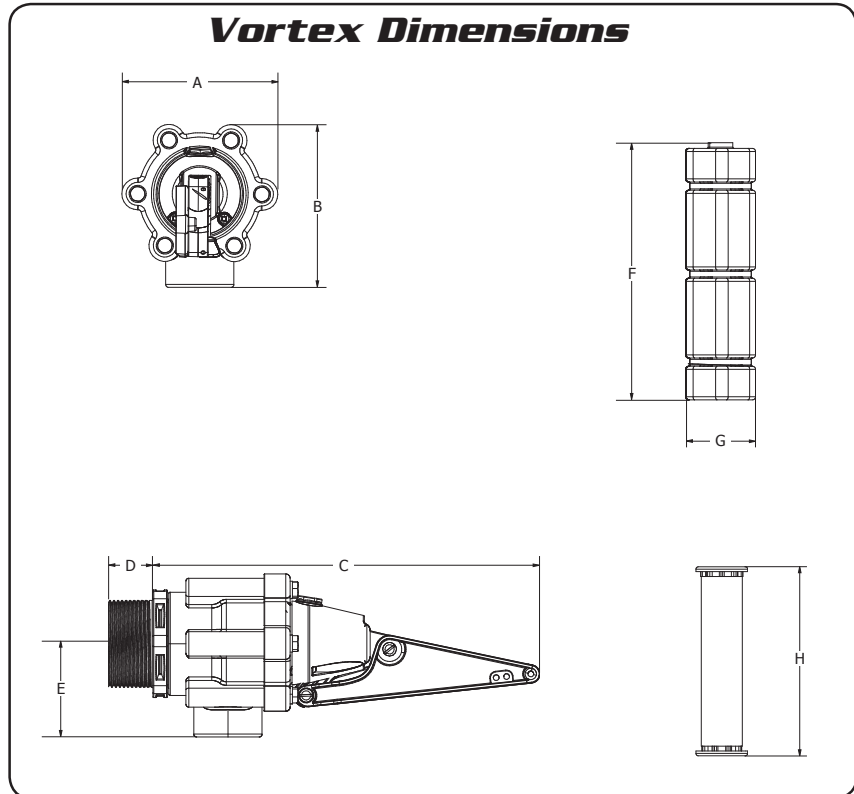
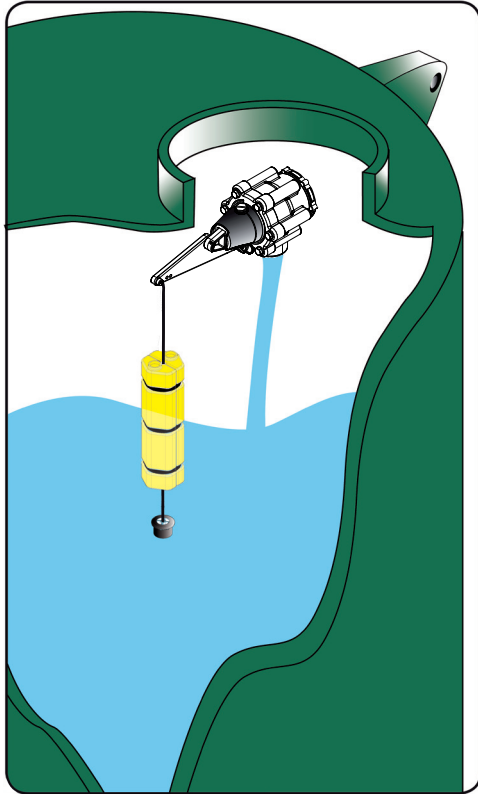

Vortex Dimensions		
	mm	inches
A	108	4 1/4
B	110	4 3/8
C	270	10 11/16
D	31	1 7/16
E	65	2 7/16
F	208	8 3/16
G	62	2 7/16
H	132	5 3/16

Materials	
Valve Body	GF Nylon
White Internal Parts	Acetal
Arm Assembly	ABS
Diaphragm	EPDM
Seal	Urethane
Springs, Bolts, Nuts, Pin, Screws	304 Stainless Steel
O'Rings	Nitrile
Float	HDPE

Maximum Temperature of Operation 60°C, 140°F