



Product Info Sheet

TOPAZ INDUSTRO FLOAT VALVE



Description

Topaz Industro Float Valves are designed to maintain water levels in applications requiring a valve with high mechanical strength and heat resistance, Industrial storage tanks and heated water cisterns. Some typical applications would be refilling cooling towers and storage tanks, High pressure cleaning and Car wash systems as well as many light industrial, Air conditioning and Irrigation installations.

Applications

Maintaining Water Levels in:

- Car wash systems
- Water Storage Tanks
- Water Cisterns
- Air Conditioning Systems
- High Pressure Cleaning Systems
- Irrigation Applications

Flow Graph

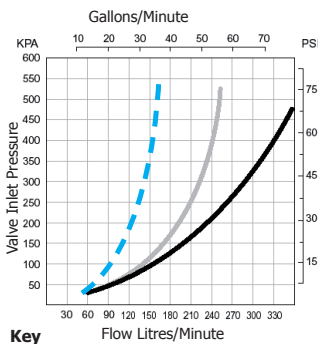

Key
 - - - 15mm (1/2")
 — 20mm (3/4")
 — 25mm & 32mm (1" & 1 1/4")

Features

- High flow
- Compact robust construction
- Maximum water temperature 80°C / 176°F
- Made from approved materials
- Mounts horizontally or vertically
- Made from corrosion resistant materials
- Shuts down slowly to minimise water hammer
- 20 - 60mm (3/4" - 2 1/2") water level differential (increases as water inlet pressure increases)
- Pressure rating 0.3 - 7 Bar (5 - 100 PSI)
- Float position easily adjustable with no tools
- Valve has switch to lock it in off position
- Has port to connect Frostpro anti freeze device

Mounting Positions

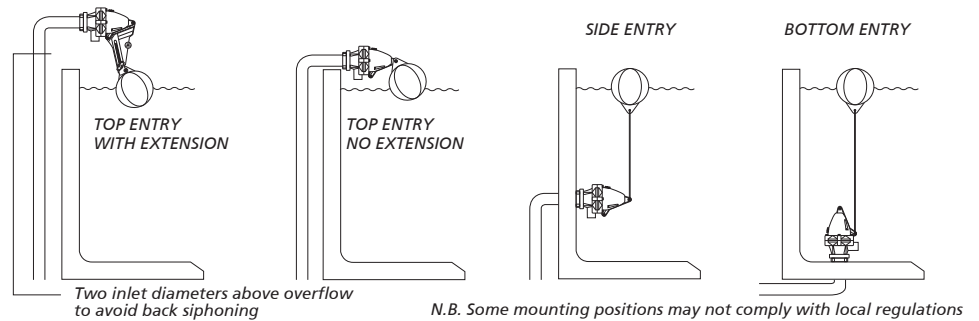

Options

| | BSP | | NPT | | Specifies this Thread size |
|------------------------|--|----|------|----|--|
| | 3/4" | 1" | 3/4" | 1" | |
| Inlet Size | 3/4" | 1" | 3/4" | 1" | |
| Detach Base Short Tail | | ✓ | | ✓ | Standard Detach |
| Detach Base Long Tail | ✓ | | ✓ | | |
| Long Tail: | Supplied with backnut and seal washer 3/4" Long Tail: 38mm long. | | | | |
| Floats: | 125mm wide floats supplied standard. Note: Suitable for any mounting position | | | | Standard: 125mm Optional: 70mm Optional: 95mm |
| | 70mm and 95mm floats optional Note: Suitable for top entry only. | | | | |

TOPAZ INDUSTRO FLOAT VALVE SPECIFICATION

| PRODUCT | CODE | INLET SIZE | CODE | OPTIONS | CODE |
|----------------------------|------|--------------|------|-----------------|------|
| Topaz Industro Float Valve | TIV | 3/4" bsp/npt | 20 | Detach Base | D |
| | | 1" bsp | 25 | Long Tail Base | LT |
| | | 1" npt | 1" | 70mm wide Float | F70 |
| | | | | 95mm wide Float | F95 |

(e.g) A Topaz Industro Float Valve with: 3/4" bsp inlet thread, detach base, long tail thread has the following spec number: TPV 20 D LT
 NOTE: If no options are specified the standard ones will be supplied

Note: Product may differ slightly from these specs due to ongoing product development.